

Evo Mobile

SLYDE

Technical information



10 year Warranty

See Warranty statement



Technical information

Configurations

- Mobile shelving unit with 4 fixed shelves and semi-open back (1)
- Mobile shelving unit with 2 fixed shelves, cabinet and semi-open back (2)
- Mobile shelving unit with 2 fixed shelves, cabinet and back panel (3)
- Mobile media wall with fixed shelf, cabinet and back panel (4)
- Mobile workstation with fixed cabinet and back panel (5)

1



2



3



4



5



Metal frame

- Welded metal tube – 1.0x1.0 inches;
- Powder coated metal.

Metal lower bases

- Metal tube – 1.97" x .98";
- In all configurations the length is 23.23", except for workstation with a desktop – the length is 25.59";
- Powder coated metal.

Footrest metal beam

- Only in the workstation configuration;
- Metal tube – Ø1.18";
- Powder coated metal (double painting).

Castors

- Four swivel castors, Ø13.92";
- With wheel brakes;
- Rotates in all directions;
- Load capacity - 220lbs per castor;
- Make sure that before relocating a unit with castors, all electrical components are disconnected from the main power source and hanged on hook of the side panel or placed securely.

Shelves

- 0.98" MFC (melamine) with 0.078 ABS edging;
- Load capacity – 55.11lbs.

Lower cabinet

- Top, bottom, side and back panels are made of 0.98" MFC (melamine) with 0.078" ABS edging;
- Sliding doors are made of 0.63" MFC (melamine) with 0.039" ABS edging;
- Dimensions: 11.02" x 22.28", H=14.56" (inner, two sections).

Desktop

- Only in the workstation configuration, order separately;
- 1" MFC (melamine) with .08" ABS edging;
- The corners of desktop are rounded - R80 mm;
- Scallop for cable management: 13.78x1.58" ;
- Optional cut-out for a power socket integration.

Fabric back panel

- Made of 0.63" chipboard;
- Covered with 3 mm foam;
- Upholstered with fabric.

Fabric and whiteboard back panel

- Fabric side is made of 0.31" MDF covered with 0.12" foam;
- Upholstered with fabric;
- Whiteboard side is made of 0.47" chipboard pressed in HPL with 0.04" ABS edging.

Perforated metal sheet back panel

- Perforated 0.039" metal sheet with a Ø0.315 hole;
- The back panel has three vertical sections with a bended central part (except a shelving unit configuration);
- Top and bottom welded with metal tube 0.78"x0.78";
- The edges are welded with metal profile;
- Matches the colour of the frame;
- Powder coated metal.

Accessories (optional)

Fabric side panel (1, 2)

- With or without a metal hook for wire management;
- 0.315" MDF covered with 0.12" foam;
- Upholstered with fabric;
- Double-sided panel hides an inner metal construction;
- Metal brackets for mounting;
- Load capacity of metal hook - 6.61lbs;
- Powder coated metal.

Perforated metal sheet side panel (3, 4)

- With or without a metal hook for wire management;
- Perforated 0.04" metal sheet with a $\varnothing 0.315$ " hole;
- Two edges are welded with metal profile;
- Fixed with screws;
- Load capacity of metal hook - 6.6lbs;
- Powder coated metal.

Side shelf (5)

- Powder coated metal;
- Should be hanged only on the crossbars of the side frame;
- Fixed with screws;
- Load capacity - 22lbs per shelf.

Hook (6)

- Powder coated metal;
- Should be hanged only on the crossbars of the side frame;
- Fixed with a screw;
- Load capacity - 11lbs per hook.

Screen holder (7)

- Two types of holders: for perforated metal back and fabric back;
- Powder coated metal;
- VESA standard – 3.94" x 3.94" ;
- Recommended screen weight is up to 33.07lbs;
- Screws for screen fixing to VESA plate are not included.

1



2



3

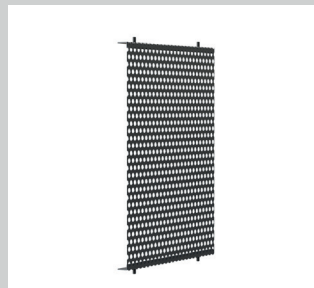

4

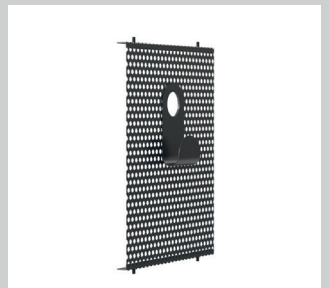

5



6



7



Range

Mobile shelving unit
with 4 fixed shelves and semi-open back

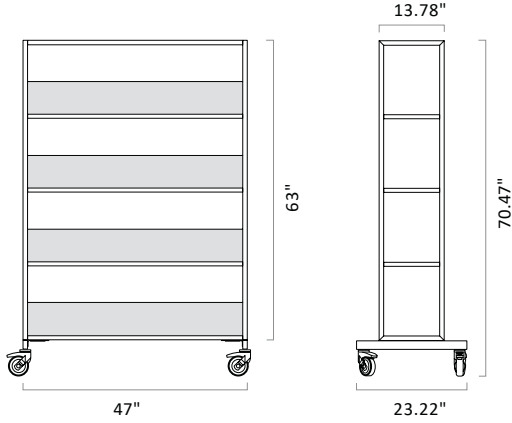

Mobile shelving unit
with 2 fixed shelves, cabinet and semi-open back

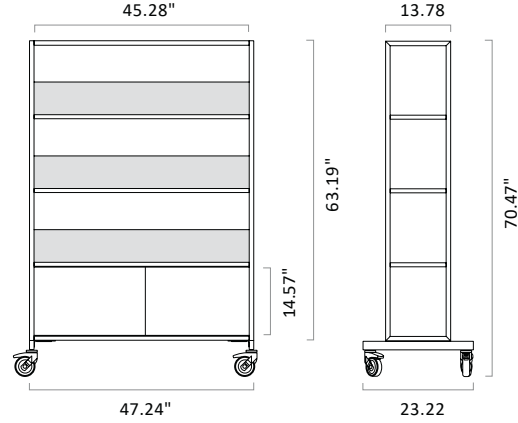

Mobile shelving unit
with 2 fixed shelves, cabinet and back panel

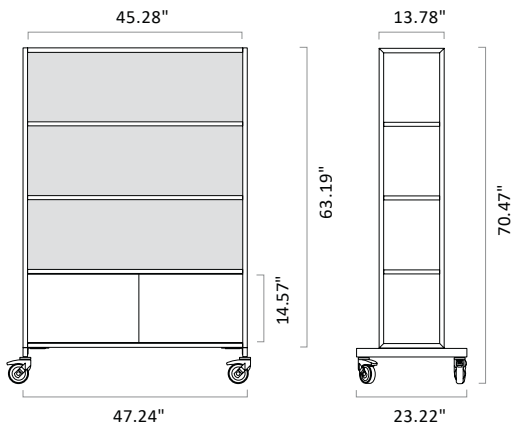

Mobile media wall
with fixed shelf, cabinet and back panel

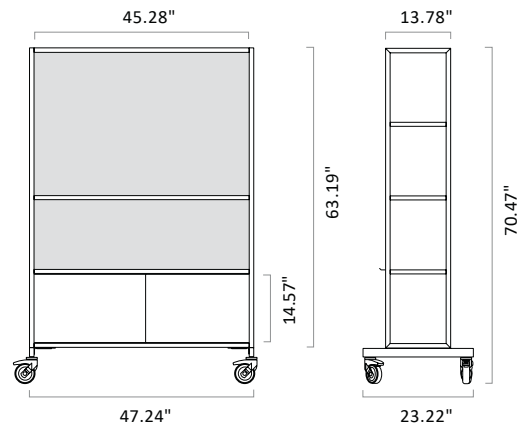

Mobile workstation
with fixed cabinet and back panel

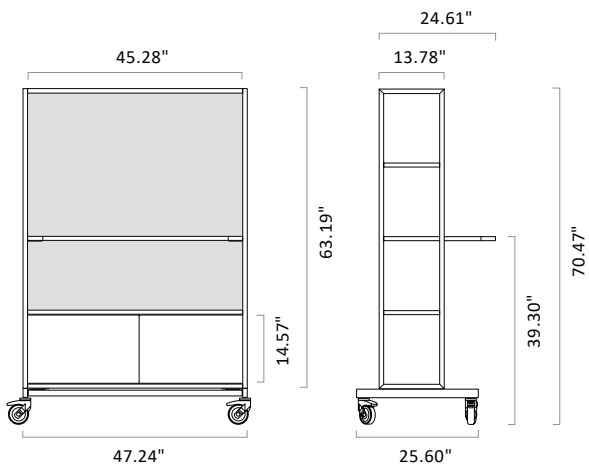

Desktop for a mobile workstation

with a scallop cut-out for wire management

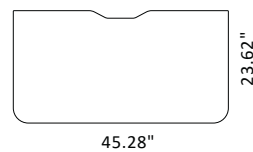

with a scallop cut-out for wire management and a cut-out for a power socket

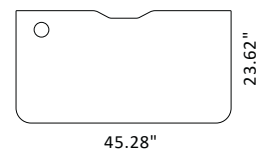

Accessories

Side panels

Perforated metal

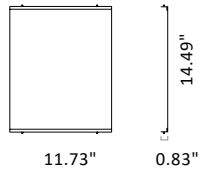

Fabric

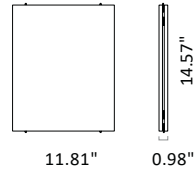

Side panel with a hook for wire management

Perforated metal

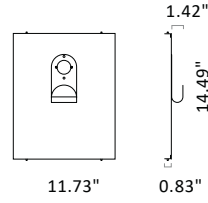

Fabric

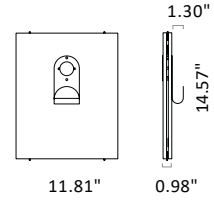

Side shelf

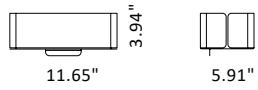

Hook

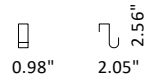

Screen holder

For the back side of perforated metal

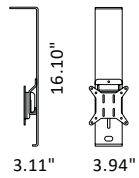

For the back side of fabric/melamine

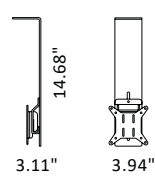

Additional information

- Only one accessory (except hook) can be fixed in the space between two crossbars of the side frame. Two hooks can be placed on one crossbar.

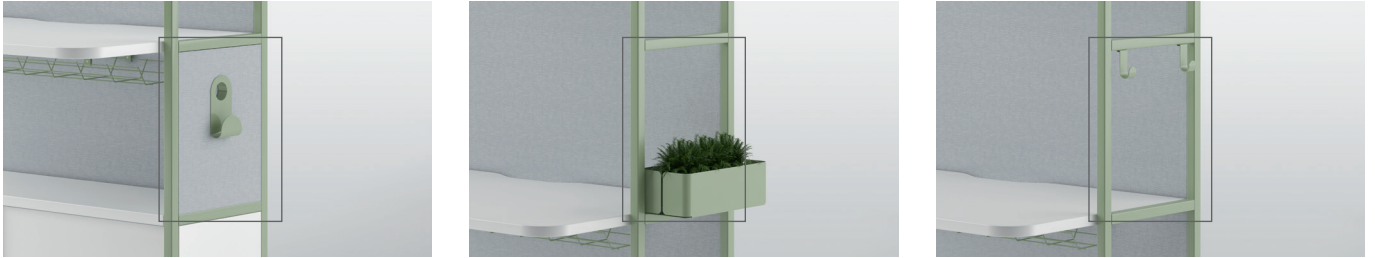

- There are two mounting options for the screen: on the front side or on the back side.



- Convenient electrical solutions for wire management. See the example below.

